



**User instruction for TTR200X electrical apparatus for use in explosion-hazardous area. Important read and understand this document before any installation.**

**ATEX Instructions**



For safe installation of the TTR200X in hazardous areas the following instructions must be observed. The transmitter must be installed by competent personnel, who are familiar with national and international laws, directives and standards that apply to their region. For installation in European Economic Area (EEA) member countries users must follow requirements for electrical equipment for use in potentially explosive atmospheres, e.g. EN60079\_14 & EN60079\_17. This instruction sheet describes installation, which conforms with BS EN60079\_14 & BS EN60079-17. Important - Particular attention must be paid to the section titled "Special conditions for safe use", failure to comply to this requirement will result in a unsafe system.

The TTR200X has been issued with a EC-type examination certificate, confirming compliance with European ATEX directive 94/9/EC for the following specification :-

**Product Information**

Following Information is printed on the product label

Manufacturer Status Instruments Ltd  
 Type Number TTR200X  
 Certificate Ref TRAC09ATEX11232X

**Zones**

Area Classification		Zone Criteria for Application Atmosphere	
Gases	Dusts		
Zone 0	Zone 20		Present continuously or for long periods (> 1000 hrs per annum)
Zone 1	Zone 21		Likely to occur in normal operation occasionally (> 10 to < 1000 hrs per annum)
Zone 2	Zone 22		Unlikely to occur in normal operation (> 10 hrs per annum)

**Classification**

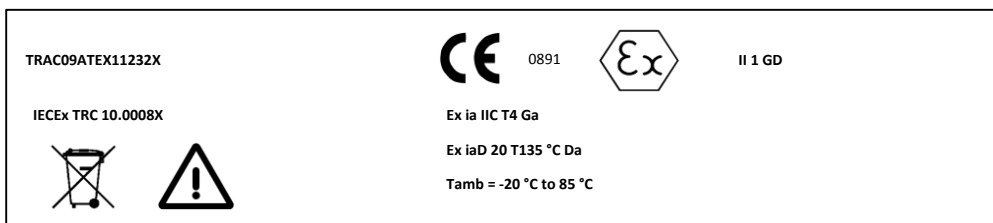

**Working Parameters**

	Terminals	
	+ / -	1 / 2 / 3
Ui =	30V	1.5V
Ii =	100mA	-
Pi =	750mW	-
Ci =	0	1.5uF
Li =	0	0
Uo =	-	5V
Io =	-	2mA
Po =	-	65mW

**Additional Information**

EMC BS EN 61326-1  
 (Sensor wires max 3 Meters to comply.)

Enclosure Color Blue

Every effort has been taken to ensure the accuracy of this document, however we do not accept responsibility for damage, injury, loss or expense resulting from errors and omissions, and we reserve the right of amendment without notice.

## Special conditions for safe use



- 1 For gas applications, the TTC200X and TTR200X temperature transmitters must be mounted in a metallic enclosure rated for IP54 and located in area where the enclosure will not be subject to impact of friction.
- 2 For dust applications, the TTC200X and TTR200X temperature transmitters must be mounted in a suitably ATEX or IECEx certified enclosure appropriate for the zone of end use .
- 3 The equipment shall only be configured by means of the USB connection outside the hazardous area.
- 4 If the equipment is mounted in an enclosure with separate IS circuits, appropriate segregation shall be provided in accordance with IEC 60079-11 Clause 6.2.1.
- 5 TTC200X - Only for connection to suitable thermocouples. These shall conform to the requirements for simple apparatus as defined in IEC 60079-0 clause 5.7 and shall pass a dielectric strength test in accordance with IEC 60079-11 Clause 6.3.12.
- 6 TTR200X - Only suitable for connection to RTD temperature sensors or slide wire resistance devices. They shall conform to the requirements for simple apparatus as defined in EN 60079-0 clause 5.7 and shall pass a dielectric strength test IAW 60079-11 Clause 6.3.12.
- 7 The ambient temperature range of the enclosure will limit the permitted ambient range of the overall equipment. Refer to enclosure certification.

## Maintenance

The appropriate regulations concerning maintenance, repair and testing must be observed. In particular, all parts on which explosion protection depends must be checked during maintenance. The transmitter must never be configured in the hazardous area, the device must be removed and taken to a non hazardous area for configuration.

The enclosure used to house the TTR200X must be cleaned regularly to prevent build up of excessive dust layers.

The TTR200X apparatus contains no user serviceable adjustable, replaceable parts. No attempt should be made to repair a TTR200X device, all units must be returned to the manufacturer for repair or replacement. Attempted service or replacement of parts may invalidate the explosive protection features of the TTR200X.

## Mechanical Detail

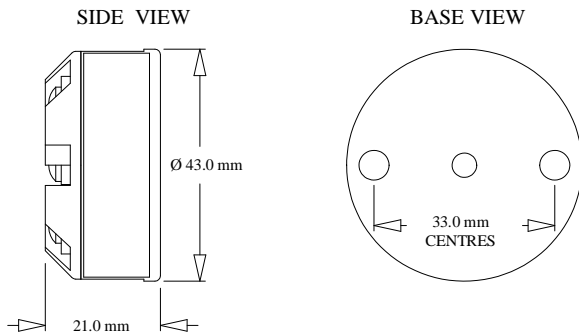

The TTR200X is mounted using two 5.5mm holes, on standard 33mm fixing centers and will fit a DIN standard termination head. The TTR200X must be installed with adequate protection from moisture and corrosive atmospheres. Refer to "special conditions for safe use" section of this user guide for information on enclosure IP rating. Care must be taken to ensure the TTR200X is located to ensure the ambient temperature does not exceed the specified operating temperature as specified in the "TEMPERATURE CLASS" table.

## Electrical Detail



REFER TO CONDITIONS FOR SAFE USE

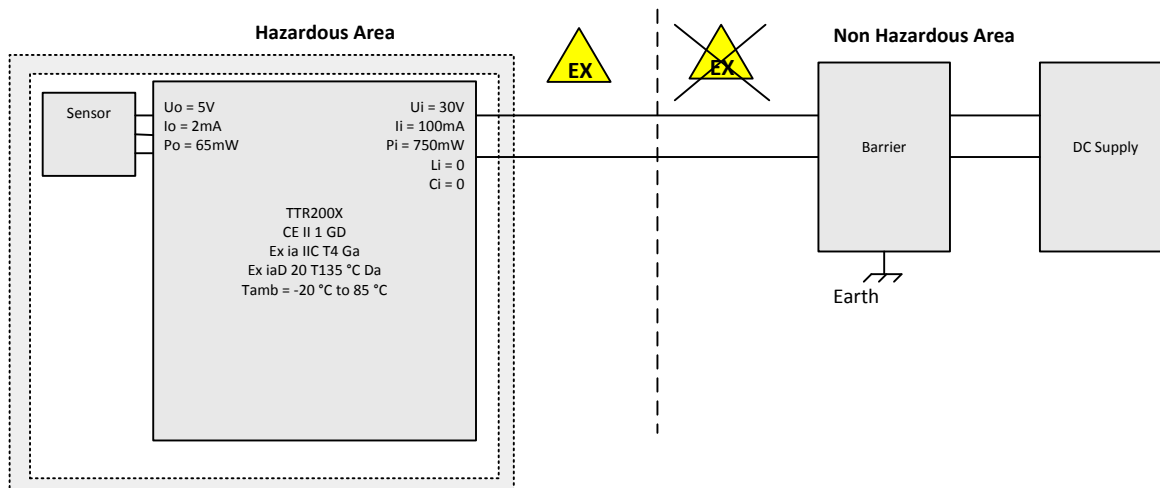

Sensor wires must be isolated from earth breakdown voltage 500VDC



For TTR200X specification please refer to product data sheet. Installation is normally performed in the following order. If the TTR200X has been purchased as part of a probe assembly, steps 1 to 3 will have been completed. The user may wish to reconfigure the transmitter range, in this instance the TTR200X range can be changed on a completed probe assembly by following step 1.

1. Configuration
2. Mount Transmitter into head
3. Wire Sensor
4. Install Assembly
5. Wire 4-20mA Loop

**1. Configuration**

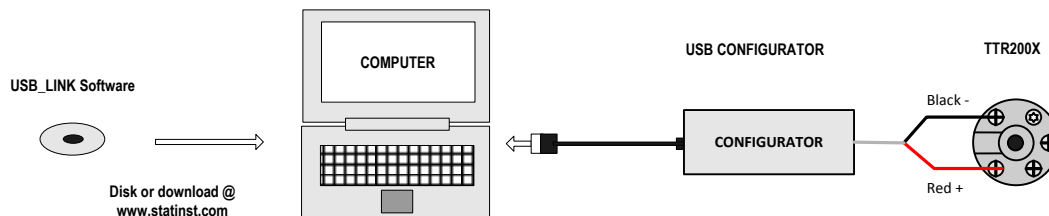

Follow the instructions provided by software menus, refer to TTR200X data sheet for list of configurable parameters.  
 Factory default Pt100 range 0 to 100 °C upscale burnout

**2. Mount Transmitter into Head**

The TTR200X is mounted using two 5.5mm holes, on standard 33mm fixing centers and will fit a DIN standard termination head. The TTR200X must be installed with adequate protection from moisture and corrosive atmospheres. Refer to "special conditions for safe use" section of this user guide for information on enclosure IP rating. A center hole is provided in the TTR200X case, this allows for sensor wire to enter wiring section through the TTR200X body. Observe the "special conditions for safe use" instruction.

**3. Wire sensor.**

Sensor connections are as follows, to maintain BS EN61326 compliance sensor wires must be less than 3 meters. All sensor connections must be isolated from ground.

Sensor RTD or Resistance 0 to 10Kohm

Slide Wire 1 to 100Kohm

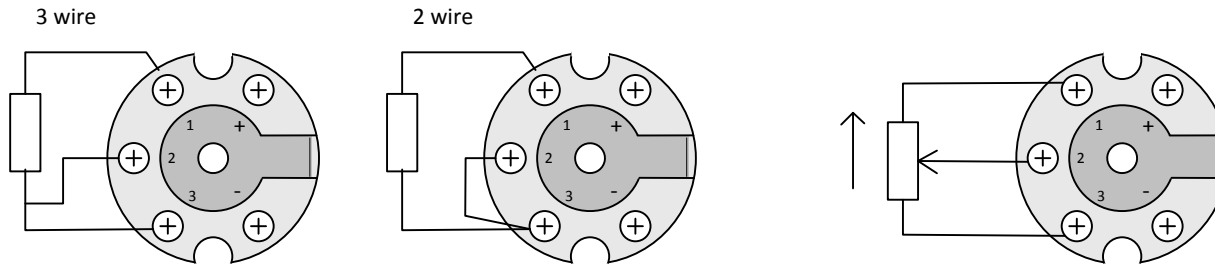

**4. Install assembly**

Care must be taken to ensure the TTR200X is located to ensure the ambient temperature does not exceed the specified operating temperature as specified in the "TEMPERATURE CLASS" table.

**5. Wire 4 to 20mA Loop**

Ensure all other aspects of the installation comply with the requirements of this document, paying particular attention to the loop barrier. The 4 to 20mA loop is connected as follows:-

