

# SEM1633 USER GUIDE DIN RAIL MOUNTED RTD/RESISTANCE/SLIDE WIRE TRIP AMPLIFIER

## ⚠ IMPORTANT - CE & SAFETY REQUIREMENTS

Important - Potentially Hazardous situations. Persons responsible for the installation and operation of this equipment must be fully aware of all aspects of this guide. Failure to follow the instructions can cause severe injuries and damage.

This product is suitable for environment Installation category II pollution degree. The product is classed as "PERMANENTLY CONNECTED EQUIPMENT", and must be DIN rail mounted, inside a suitable enclosure providing environmental protection to IP65 or greater.

DC supply must be derived from a local supply and not a distribution system. Max relay contact rating 250VAC @ 1A or 30VDC @ 1A. Any circuit connected to a contact must be fused with a 2A (T) fuse.

To maintain CE EMC requirements, input and supply wires must be less than 30 meters. The product contains no serviceable parts, or internal adjustments. No attempt must be made to repair this product. Faulty units must be returned to supplier for repair. This product must be installed by a qualified person. All electrical wiring must be carried out in accordance with the appropriate regulations for the place of installation. Before attempting any electrical connection work, please ensure all supplies are switched off.

ABSOLUTE MAXIMUM CONDITIONS (To exceed may cause damage to the unit):-

Supply Voltage	± 50VDC (Protected for over voltage and reverse connection)
Current with over voltage	± 200mA
Input Voltage	± 5VDC between any terminals
Input Current	± 10mA between terminals
Ambient	Temperature -30 to 75°C Humidity 10 to 95% RH (Non condensing)



PLEASE REFER TO THE PRODUCT LABEL FOR MANUFACTURERS CONTACT DETAILS.

Every effort has been taken to ensure the accuracy of this document, however we do not accept responsibility for damage, injury, loss or expense resulting from errors and omissions, and we reserve the right of amendment without notice.

## RECEIVE AND UNPACKING

Please inspect the packaging and instrument thoroughly for any signs of transit damage. If the instrument has been damaged, please notify your supplier immediately.

## OPERATION (please refer to data sheet for full technical specification.)

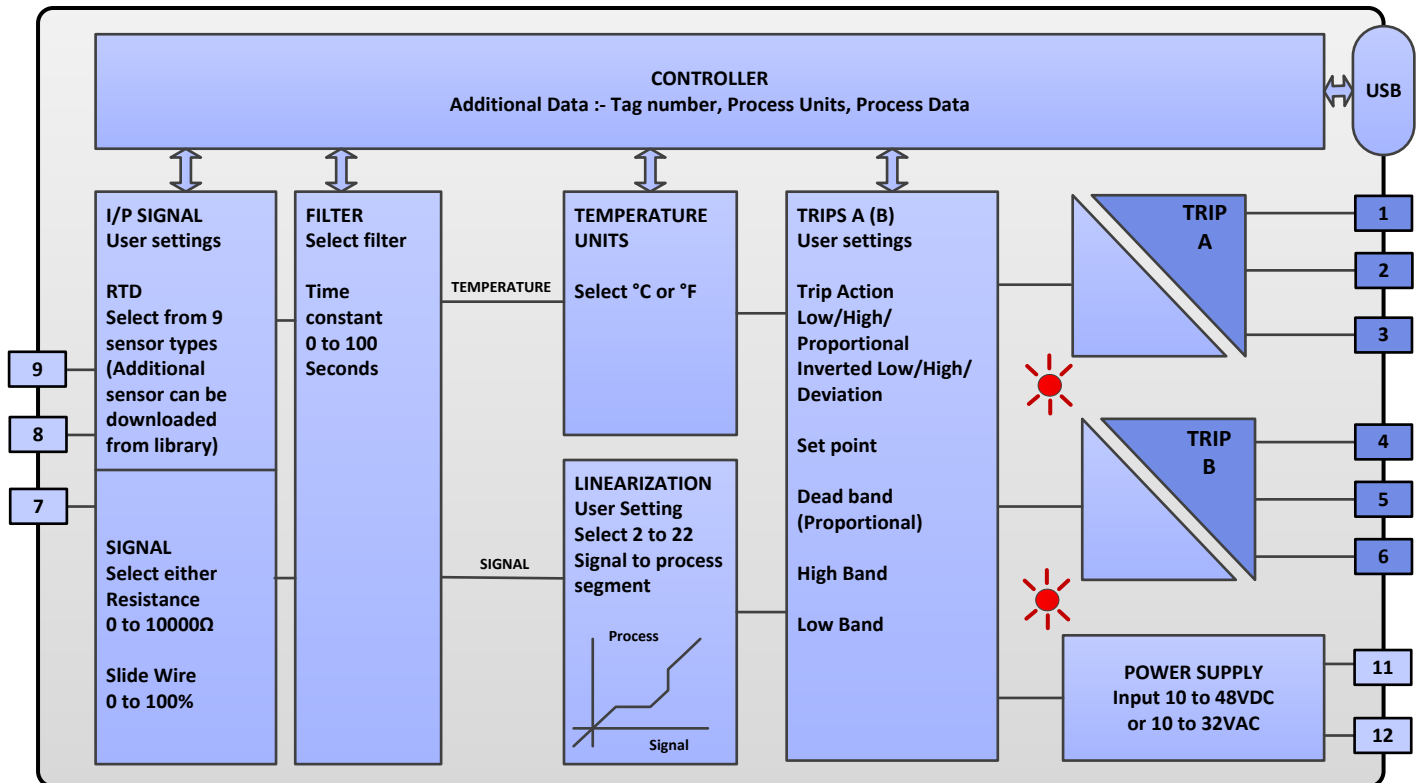

### RANGE LED



### ALARM LEDS



### POWER OFF

When power is off relays go into alarm state.

### TRIP ACTIONS

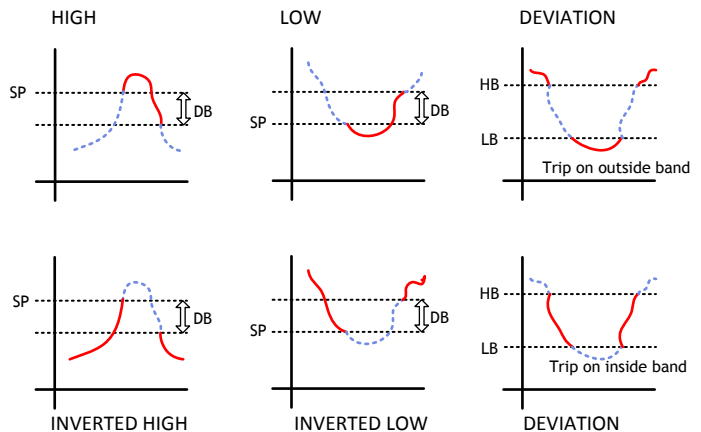
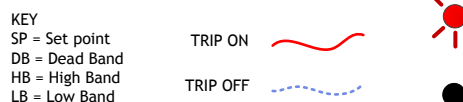

## MECHANICAL INSTALLATION

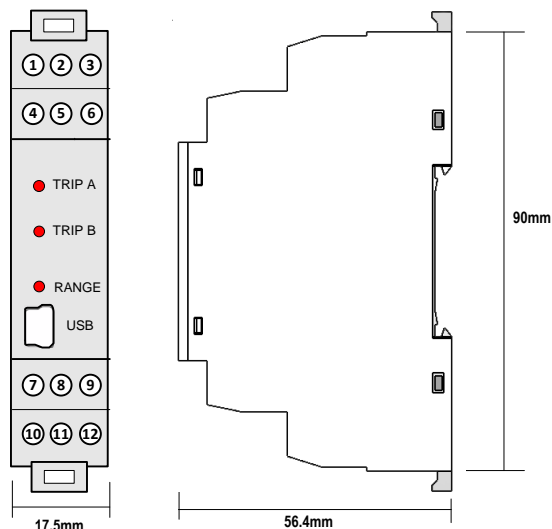

Style DIN 43880 (1 module width)  
 Material Polyamide 6.6 self extinguishing  
 Terminals Screw terminal  
 Cable 2.5mm Max  
 Color Gray

### MOUNTING

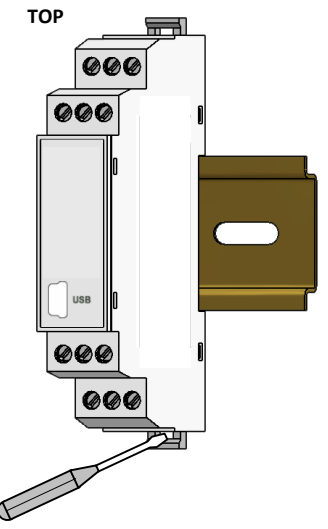
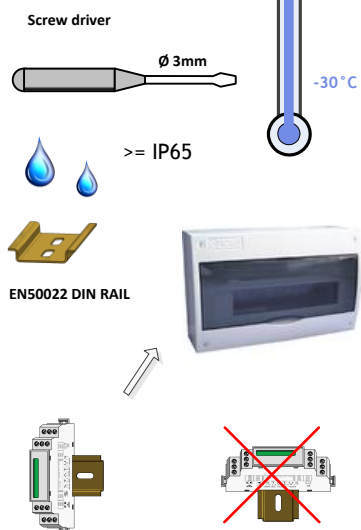

To fit or release module  
 Insert screw driver into slot and lever latch away from body

## CONFIGURATION

This product is configured using the USB port of a PC running USB\_Speed\_Link software, available from your suppliers web site. During configuration the product is powered direct from the USB port, removing the need for additional power. If the user wishes to monitor live process data during configuration, then power must be applied. Note the input and USB port of the device share the same ground, therefore care must be taken to ensure isolation between PC and input circuit. This is best achieved by using a portable laptop or notebook PC. USB\_Speed\_Link software is provided with detailed help menu to guide the user through the simple configuration procedure. Unless specified at the time of order this product is supplied with the default configuration listed below.



Factory default:  
 Input type = Pt100  
 Units = °C  
 Trip A = High  
 Setpoint Trip A = 50  
 Hysterisis Trip A = 0.1  
 Trip B = High  
 Setpoint Trip B = 50  
 Hysterisis Trip B = 0.1  
 Filter = 0

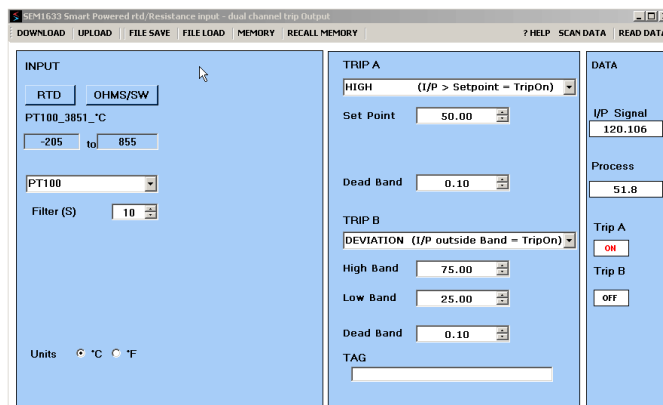

## ELECTRICAL INSTALLATION

- 1.0 TURN OFF SUPPLY BEFORE WORKING ON ANY ELECTRICAL CONNECTION.
- 2.0 MAX CONTACT RATING 250VAC or 30VDC @ 1A. IMPORTANT! FUSE CONTACT CIRCUITS 2A (T).
- 3.0 SUPPLY IS OVER VOLTAGE PROTECTED AND FUSED WITH INTERNAL RESETTABLE FUSE.

### INPUT CONNECTION

For cable length < 3 Meters no shield or twist pair required.  
 RTD inputs all three wire must be equal length (resistance).  
 Use recommended types for cable length 3 to 30 meters.

