

- HART® PROTOCOL
- UNIVERSAL INPUT
- SENSOR BURNOUT DETECT
- ISOLATION TO 500VAC
- ENCAPSULATED

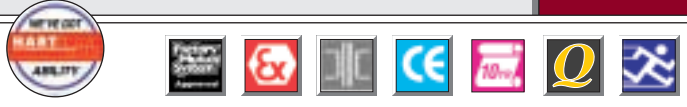

HART IN-HEAD TEMPERATURE TRANSMITTER SEM310

INTRODUCTION

The SEM310 is a field mount temperature transmitter designed to replace the terminal block in a sensor head. It is fully encapsulated to ensure environmental integrity. Although small in size it out performs other larger and more expensive transmitters. Also available in DIN rail mount format packaging SEM315 series.

The SEM310 has full HART communications protocol which allows the user to quickly and easily down-load information or interrogate the device enabling the following:-

- Simple re-ranging of sensor type and range.
- Easy on site re-calibration
- Self documentation.
- Operation with proprietary software packages such as AMS Plant Web™ and Cornerstone™
- Remote configuration on the 4-20mA loop with a hand held communicator or with a PC & HART modem.
- Online Digital communication concurrent with a 4-20mA Analog signal

All the standard HART universal and common usage commands are fully implemented, with other device specific commands that enable access to the enhanced performance parameters of the SEM310.

Some of the enhanced SEM310 features are as follows;

Sensor Referencing

The SEM310 sensor referencing via the Windows based RCP2 software allows for close matching to a known reference sensor eliminating possible sensor errors.

User calibration

In addition to sensor referencing, user offset and current output trimming is possible via the HART commands.

Custom Linearisation

The [X]*1 facility allows the SEM310 to be programmed with a custom linearisation to suit non standard sensors or sensors with unusual or unique characteristics. Consult the sales office for details.

Sensor Burn out detection

If any sensor wire is broken or becomes disconnected the SEM310 output will automatically go to its user defined level (upscale or downscale). This happens irrespectively of which wire is broken.

Output current preset

For ease of system calibration and commissioning the output can be set to a predefined level anywhere in the 4-20mA range

HART® Registered trademark of the HART Communication Foundation.

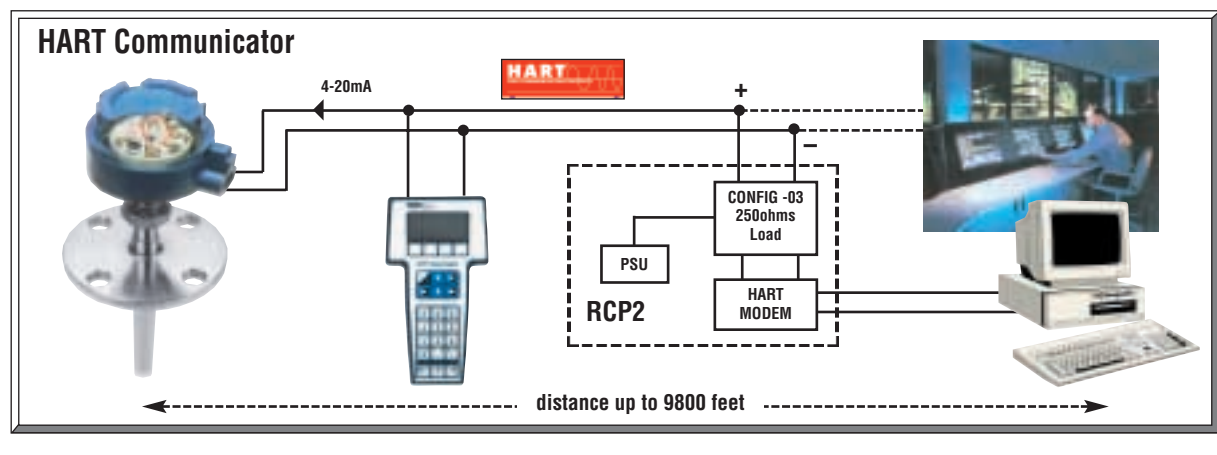

STATUS INSTRUMENTS INC.
 PO Box 548, 456 Park Ave., Scotch Plains, NJ 07076
 Phone: (800) 700-3272 Fax: (800) 700-5468 (US & CA only)
 Phone: (908) 490-0232
 Email: rc@statinst.com Internet Address: www.statinst.com



SEM310 PDF 6.03

GENERAL SPECIFICATION @ 68°F

Input types	Pt-100, Thermocouple, mV or Slidewire. (Ni-100, via Custom [X] ^{*1} facility)
Time constant (Filter off)	0.5secs (to 90% of final value)
Filter Factor	Off / selectable between 1 and 32 seconds / or Adaptive
Warm-up time	2 minutes to full accuracy
Input/Output Isolation	500VAC tested to 3000VAC
Re-calibration interval	1 year, to maintain accuracy to published specification 5 years, to maintain accuracy to less than twice published specification

ENVIRONMENTAL

Operating range	-40 to +185°F
Storage temperature	-58 to +185°F
Humidity range	0 to 100% (non condensing)

APPROVALS

Designed and manufactured under a Quality Management System to BS.EN. ISO 9001.

EMC Emissions	EN50081-1
EMC Immunity	EN50082-2
Hazardous Area	FM3610 Ex ia IIC T4..T6
Increased Safety	Ex N IIC

OUTPUT

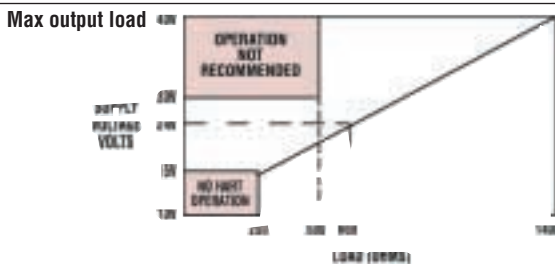

$[(V_{supply} - 10)/21]$ KΩ 250 ohm minimum loop load. Supply voltages over 30V a minimum loop load of 500 ohms is necessary.

Output range	4-20mA (Min 3.8 to Max 20.2mA)
Accuracy	±5µA
Thermal Drift	0.05µA/ °F
Supply Voltage	10 to 40V DC
Supply Voltage effect	0.2µA/V

ENCLOSURE

Material	ABS
Flammability	SEI UL94-V0

Notes

- *1 Custom characterisation is available pre-programmed at the factory, contact your nearest Sales office.
- *2 Includes the effect of calibration, linearisation and repeatability
- *3 Consult Thermocouple reference tables for practical temperature ranges.
- *4 FRI = Full Range Input
- *5 Any span may be selected but full accuracy is only guaranteed for spans greater than the minimum specified.

INPUT SENSORS & RANGES

Pt-100 (RTD) 2, 3 or 4 Wire

Sensor Range	-328 to +1562°F [18-390 ohms]
Minimum Span ^{*5}	77°F
Linearisation	BS EN 60751/BS1904 DIN43760/JIS1604 CUSTOM [X] ^{*1}
Max lead Resistance	50 ohms per leg (balanced for 3 wire)
Basic Measurement Accuracy ^{*2}	0.01% FRI ^{*4} ±0.07% rdg
RTD excitation current	300µA to 500µA
Thermal Drift	Zero 0.008°F/°F Span 50ppm/°F

THERMOCOUPLE

Type	Range ^{*3}	Minimum span ^{*5}
Type K	-328 to 2450°F	90°F
Type J	-328 to 2192°F	90°F
Type T	-346 to 752°F	45°F
Type R	14 to 3200°F	180°F
Type S	14 to 3200°F	180°F
Type E	-328 to 1832°F	90°F
Type F(L)	-148 to 1112°F	45°F
Type N	-292 to 2372°F	90°F
Others [X] ^{*3}	±9999	Custom ^{*1}

Linearisation	BS EN 60584-01/ BS 4937/ IEC 584-1
Basic Measurement Accuracy ^{*2}	0.04% FRI ^{*4} ±0.04% RDG or 1°F (whichever is greater)
Cold junction	± 1°F tracking range 0.05°F/°F -40 to +185°F
Thermal Drift	Span 50ppm/°F

MILLIVOLTS

Input	Voltage source
Range	-10 to +75mV
Characterisation	Linear, Custom [X] ^{*1}
Minimum Span ^{*5}	5mV
Basic Measurement Accuracy ^{*2}	±10µV ± 0.07% Rdg
Input Impedance	10Mohm
Thermal drift	Zero 0.05µV/°F Span 50ppm/°F

SLIDEWIRE

Input	3 wire potentiometer
Resistance Range	10-390 Ohms end to end (Larger values can be accommodated with an external resistor)
Range	0-100%
Characterisation	Linear, Custom [X] ^{*1}
Minimum Span ^{*5}	5% of FRI ^{*4}
Thermal Drift	Zero 0.005% of Span/°F Span 50ppm/°F
Basic Measurement Accuracy ^{*2}	0.1% of FRI ^{*4}

RCP2 SOFTWARE

Communicating with the SEM310 HART transmitters

The SEM310 can communicate digitally, concurrent with the analog 4-20 mA output signal. This can be achieved in a number of ways namely:

- Proprietary hand held communicator
- PLC's, DCS's etc with HART interface
- PC Computers using RCP2 and a HART modem.

Communicating with a Hand Held Communicator

The SEM310 will communicate with any proprietary HART communicator and access to all universal commands is available from the communicator. In order to access all the parameters available, the communicator must have the correct HART Device Description (DD) installed. Contact the communicator provider or 'Support @ Status' to enable up-grading of communicators that do not contain the correct DD.

Communicating with PLCs or DCSs

Any system that supports HART field devices using such software packages as AMS-Plant Web™ or Cornerstone™ will communicate with the SEM310 enabling access to advanced system features such as self documentation and diagnostics. The correct DD must be installed for full access to all parameters.

Communication with a PC

Communication with a PC is easily accomplished by using the HART modem supplied with the communications kit, and RCP2 software. RCP2 is the menu-driven software product from Status Instruments which runs under Windows 95, 98 or NT and enables the following functions to be quickly and easily performed:

- Change sensor type, range, select burnout direction. filter(damping) factor
- Set tag numbers, assembly numbers, calibration details, messages etc
- Print or save to file all relevant documentary information
- Read next calibration date
- Perform basic calibration
- Monitor sensor status and read transmitter diagnostics
- Real-time reading of process variable
- Supports up to 15 devices in multi-drop mode

RCP2 software is very 'User-friendly' and can be used immediately without extensive training. The user is guided through a series of simple menu screens where the information is clearly and logically represented. It is available in English and many other languages (contact sales office for latest information).

HART Field Communication Protocol

HART (Highway Addressable Remote Transducer) is a communications protocol used to 'talk' to field devices digitally while, at the same time, using the industry standard 4-20 mA analog transmission. It is widely used in process industries such as chemical, oil refining, pulp and paper, food and pharmaceuticals.

The HART protocol uses the Bell 202 frequency-shift-keying (FSK) standard to superimpose a sinusoidal signal on top of a 4-20 mA analog signal, a logical '1' being represented by 1.2K Hz and '0' by 2.2K Hz. The FSK technique means that digital signals and the analog 4-20 mA can be used concurrently, thus HART provides bi-directional digital data interchange whilst maintaining compatibility with older 4-20mA systems. Although it was originally conceived as a master-slave, single loop implementation with up to two masters, there is also a multi-drop operating mode accommodating up to 15 slave devices.

The protocol provides three command groups:-

Universal Commands.

These provide functions that must be implemented in all field devices, such as "Read unique identifier (manufacturer, device type etc) or "Read Primary Variable (PV)".

Common Practice Commands.

These provide functions common to many, but not all, field devices, for example "Write transmitter range values", " Write PV Units".

Device Specific Commands.

These provide functions which are more specific to a particular device, for example "Read Sensor Type. No of wires, burnout"

Multidrop HART

As well as operating in standard mode the SEM310 supports HART Multidrop mode whereby up to 15 devices can be connected to the same pair of wires enabling full digital functionality with each device.

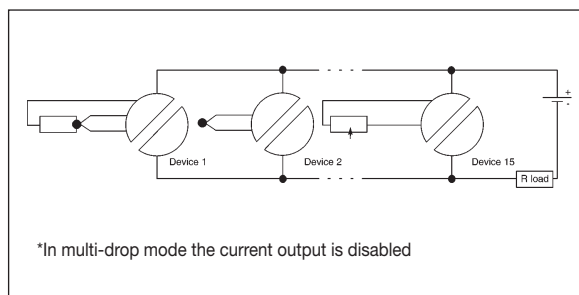

Continued overleaf

HART Field Communication Protocol continued

Group	Command	Description
Universal Commands	0	Read unique identifier
	1	Read primary variable
	6	Write polling address
	11	Read unique identifier associated with tag
	12	Read message
	13	Read tag, descriptor, date
	14	Read PV sensor information
	15	Read output information
	16	Read final assembly number
	17	Write message
Common-Practice Commands	18	Write tag, descriptor, date
	19	Write final assembly number
	34	Write damping value
	35	Write range values
	40	Enter/exit fixed current mode
	44	Write PV units
	45	Trim DAC zero
Device-Specific Commands	46	Trim DAC gain
	48	Read additional transmitter status
	130	Read sensor type, no. of wires, burnout
	131	Write sensor type, no. of wires, burnout

The table shows the range of HART commands implemented in the SEM310. Full access to all these parameters is available via a PC running RCP2 but in order to gain access to the full list from a third party communicator, the correct Device Description Language must be installed. Contact Status Instruments Ltd for communicator upgrade.

The increasing use of 'Smart' equipment will see a marked rise in the application of digital field bus technology, of which HART may be considered to be the most widely available with the most installations. With the trend towards smarter systems with all the advantages that they offer to the user and the falling cost of HART products, many customers now expect to have HART protocol as standard in any instrument that they purchase.

More information can be obtained on HART from the HART Communication Foundation on their web site at <http://www.hartcomm.org>

HAZARDOUS AREA

Available for mounting in flammable atmospheres approved to EEx ia IIc T4..T6, FM3610 or Ex NII.

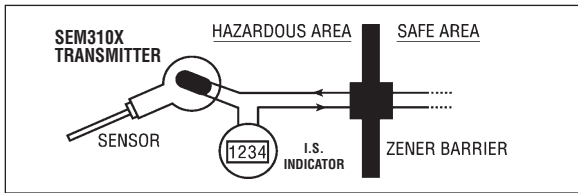

TYPICAL 200 SERIES SENSOR ASSEMBLY

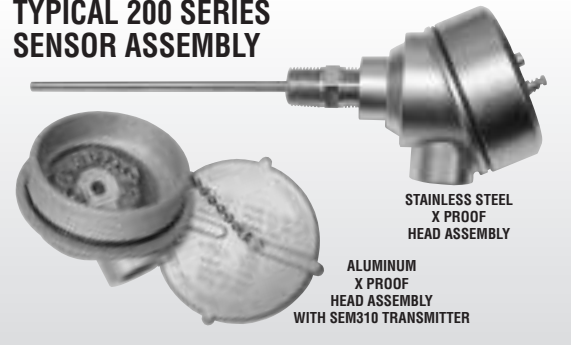

ORDER CODE

- SEM310** HART transmitter Standard Unit. (Default Pt-100 range 0-100°C)
- SEM310X** I.S. version
- CONFIG 310** Pre Configured to customers specified range
- Software**
- RCP2** Software, & manual, also available via internet www.statinst.com
- Accessories**
- RCP2-KIT-USA** Programming Kit comprising; RCP2, PSU, CONFIG-03, HART modem
- RMK-1** Din Rail Adapter

SEM310 Connections

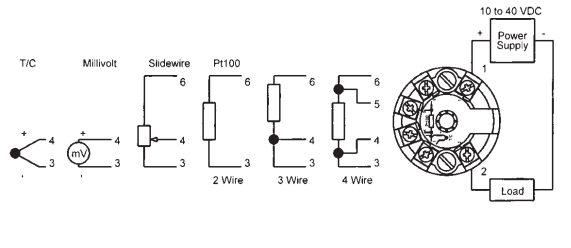

Mechanical Details Weight 1.5 oz. (43g)

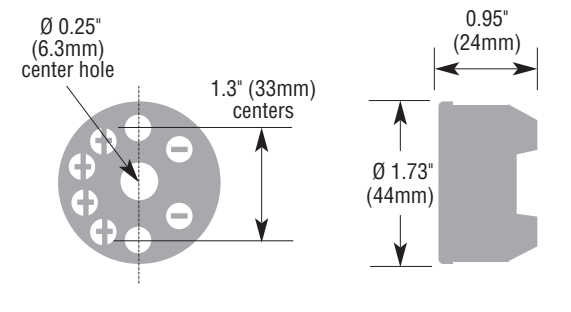

LOCAL REPRESENTATION

Every effort has been taken to ensure the accuracy of this specification, however we do not accept responsibility for damage, injury, loss or expense resulting from errors and omissions, and we reserve the right of amendment without notice.